

Flanged Thermowells

Model SF, RF and HF

According ANSI/ASME or DIN 43772

Features

- Solid bore construction
- Materials according ISO 15156/NACE MR 01-75
- Selection of materials
- Standard and customer specifications
- DIN and ANSI/ASME process connections

Ratings

DIN up to PN100

ANSI/ASME up to 2500 lbs

Applications

Chemical and petrochemical industry

Machine and apparatus construction

Food and beverage industry

Pulp and paper industry

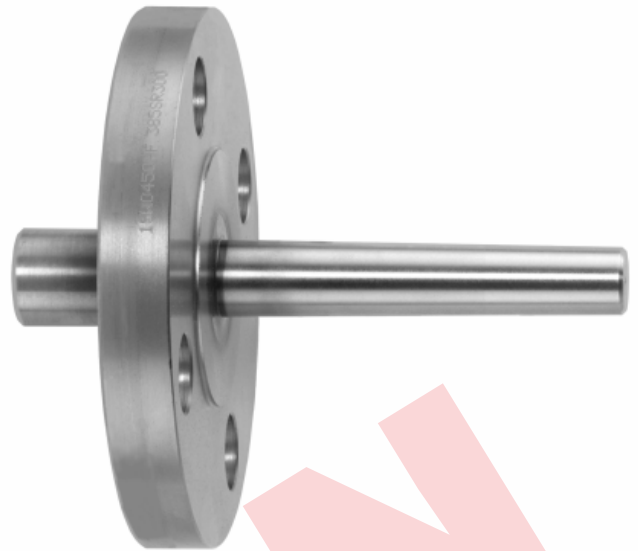

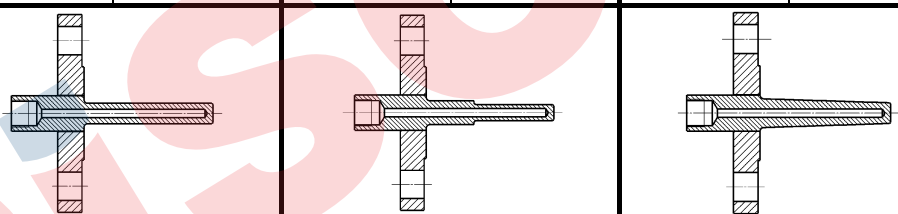
Technical specification	SF	LSF	RF	LRF	HF	LHF
Solid bore design	 <p>Shank solid bore, flange welded on shank standard. Optional one piece design, built up design or to customer specification</p>					
Construction shank Lagging	Straight No Yes		Stepped No Yes		Tapered No Yes	
Standard lengths	3" (75 mm), others on request					
Standard U-length [inch] [mm]	2 51	4 101,5	7 178	10 254	13 330	16 406,5
Bore diameter [inch] [mm]	0,260 0,385 ¹⁾ 6,6 8,5 ¹⁾ 9,8 ¹⁾ 10,5 ¹⁾ Others on request, see coding table					
Pressure rating Process connection DIN Size Pressure class ANSI/ASME Size [inch] Pressure class [lbs] Facing	Depending on flange rating DN25, DN40, DN50, DN80, DN100, others on request PN10, PN16, PN25, PN40, PN64, PN100, others on request 1, 1½, 2, 3, 4, others on request 150, 300, 600, 900, 1500, 2500 R (raised face), F (flat face) ¹⁾ , J (ring joint type) Other forms, connections or standards are available on request					
Instrument connection	½ NPSM female standard, optional ½ NPT female or G ½ female					
Material	Stainless steel 304 (1.4301), 304L (1.4306), 316 (1.4401), 316L (1.4404), 316Ti (1.4571) Monel, Hastelloy B, Hastelloy C, Inconel, Tantalum, Duplex, Nickel Other materials or coatings on request					
Certifications & tests	Material certificate DIN EN 10 204 3.1, Hydrostatic test, dye penetration test, X-ray, Hardness test, ISO 15156/NACE certificate, stress calculation according to ASME Power Test Code 19.3 or Design Memo No. T/115					
Accessories, options	Thermometers, Pt-100, thermocouples					

General dimensions [inch (mm)]

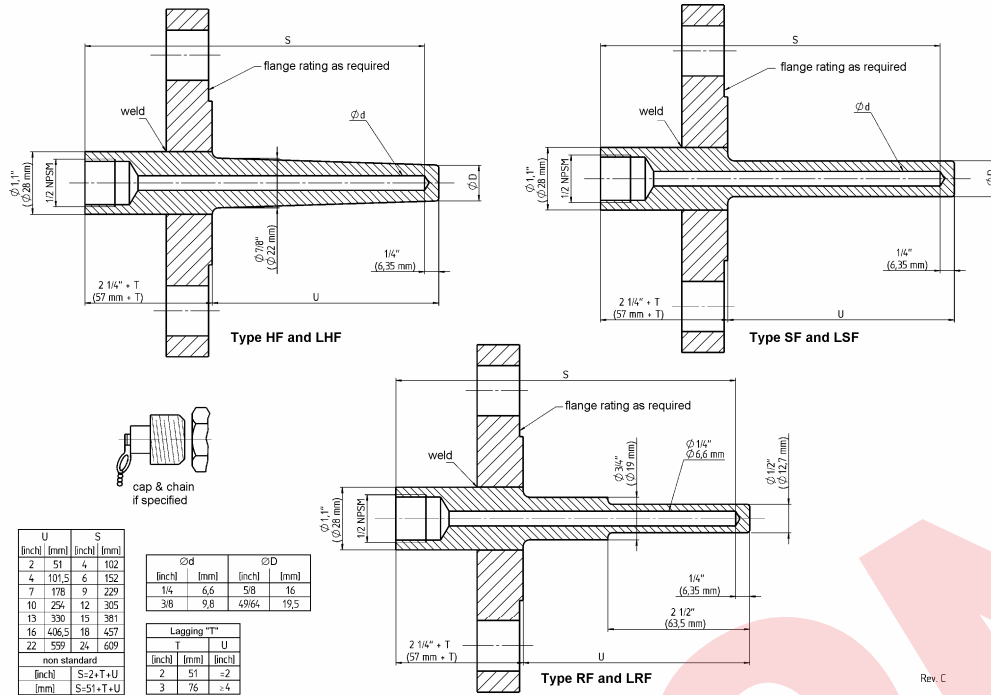

Order information

Process connection	U-length	Instrument connection	Lagging	Type	Bore	Material ¹⁾	Flange facing	Pressure rating	Options
(10) 1" (DN25)	Inch dimension (0200) 2"	All connections are female (=) 1/2 NPSM	(=) No lagging	(HF) Standard with Welded Flange Tapered Shank	Inch dimensions (260) 0,260" (6,6 mm)	(C) 304 (1.4301)	ANSI Flange	ANSI Flange	(NH) Tagging stamped
(15) 1 1/2" (DN40)	(0400) 4"	(50) 1/2 NPT	(L) With lagging (standard 3" (75mm), other lengths to be specified in [inch] or [mm])	(SF) Welded Flange Straight Shank	(385) 0,385" ¹⁾ (9,8 mm)	(CL) 304L (1.4306)	(R) Raised face	150 300 600 900 1500 2500	(BP) Buffed and polished
(20) 2" (DN50)	(1000) 10"	(51) G 1/2		(RF) Welded Flange Stepped Shank (only bore 0,260 (6,6mm))	others on request	(S) 316 (1.4401)	(F) Flat face ¹⁾		(FL) Specify flange as per material code (e.g. FLM flange material Monel)
(30) 3" (DN80)	(1300) 13"					(SL) 316L (1.4404)	(J) Ring joint type		(CD5) certificate ISO 15156
(40) 4" (DN100)	(1600) 16"					(M) Monel	¹⁾ only for < 2500 lbs and < 3"		(CDW2) Dye penetration test
	(2200) 22"					(H) Hastelloy C			(CDRH) Rockwell hardness test
	MM dimension (... mm) length in mm				MM dimension (... mm)	(N) Nickel	DIN flange	DIN flange	(X-RAY) X-ray photo
					standard available	(DU) Duplex	the flange facing depends on the process connection (nominal size and nominal pressure)	PN10 PN16 PN25 PN40 PN64 PN100	Material certificates acc. DIN EN 10 204
					6,6 mm ¹⁾ 8,5 mm ¹⁾ 9,8 mm ¹⁾ 10,5 mm ¹⁾				(CD2) 2.2
					¹⁾ not for type SM, LSM, RT and LRT	¹⁾ flange material is the same as the shank material unless specified with code (FL.), see options			(CD3) 3.1
others on request	others on request	others on request		other construction such as: Solid machined, built up and to customer specification on request	others on request	others on request	others on request		Hydrostatic internal pressure test
									(CDW9) 100 bar 1 min.
									(CDW4) To customer specification

How to order

Process connection	Type	U-length	Instrument connection	Lagging	Shank type	Bore diameter	Material	Flange facing	Pressure rating	Options
10	W	0200	=	L	HF	260	SL	R	150	2

Ashcroft Instruments GmbH

Germany
Max-Planck-Str. 1, D-52499 Baesweiler
P.O. Box 11 20, D-52490 Baesweiler
Tel.: +49 (0) 2401 808-0, Fax: +49 (0) 2401 808-125

France
„206“ ZA Le Mandinet Rue des Campanules
F-77185 Lognes
Tel.: +33 (0) 1 60 37 25 30, Fax: +33 (0) 1 60 37 25 39

Website: www.ashcrofteurope.com

e-Mail: sales@ashcrofteurope.com

United Kingdom

Unit 5 William James House
Cowley Road, Cambridge CB4 0WX
Tel.: +44 (0) 12 23 39 55 00, Fax: +44 (0) 12 23 39 55 01